

# Data sheet

Title: METAL-PLATE CHIP RESISTOR; LOW OHM

Style: MLP63C

AEC-Q200 qualified

RoHS COMPLIANCE ITEM  
Halogen and Antimony Free

- Note:
- Stock conditions  
Temperature: +5°C ~ +35°C  
Relative humidity: 25% ~ 75%  
The period of guarantee: Within 2 year from shipment by the company.  
Solderability shall be satisfied.
  - Product specification contained in this data sheet are subject to change at any time without notice
  - If you have any questions or a Purchasing Specification for any quality Agreement is necessary, please contact our sales staff.



**釜屋電機株式會社**  
**KAMAYA ELECTRIC CO., LTD.**

Hokkaido Research Center  
Approval by: T. Sannomiya  
Drawing by: M. Shibuya

## 1. Scope

1.1 This data sheet covers the detail requirements for metal-plate chip resistor ; low ohm, style of MLP63C.

### 1.2 Applicable documents

JIS C 5201-1: 2011, JIS C 5201-8: 2014, JIS C 5201-8-1: 2014

IEC60115-1: 2008, IEC60115-8: 2009, IEC60115-8-1: 2014

## 2. Classification

Type designation shall be the following form.

(Example) 

RLP	63C	K	R010	F	TE
1	2	3	4	5	6
Style					

1 Metal - plate chip resistor; low ohm  Style

2 Size

MLP63C	6332 size, 3W
--------	---------------

3 Temperature coefficient of resistance

N	$\pm 70 \times 10^{-6} / ^\circ\text{C}$
K	$\pm 100 \times 10^{-6} / ^\circ\text{C}$

4 Rated resistance

1L50	1.5m $\Omega$
R002	2m $\Omega$

5 Tolerance on rated resistance

F	$\pm 1\%$
J	$\pm 5\%$

6 Packaging form

TE	Embossed taping:
----	------------------

### 3. Rating

3.1 The ratings shall be in accordance with Table-1.

Table-1

Style	Rated dissipation (W)	Rated current (A)	Temperature coefficient of resistance ( $10^{-6}/^{\circ}\text{C}$ )		Rated resistance (m $\Omega$ )	Tolerance on rated resistance
MLP63C	3.0	77.4	K	100	0.5	J( $\pm 5\%$ )
			N	$\pm 70$		
		54.7	K	100	1	F( $\pm 1\%$ ) J( $\pm 5\%$ )
			N	$\pm 70$		
		44.7	K	100	1.5	
			N	$\pm 70$		
		38.7	K	100	2	
			N	$\pm 70$		
		34.6	K	100	2.5	
			N	$\pm 70$		
		31.6	K	100	3	
			N	$\pm 70$		
		27.3	K	100	4	
			N	$\pm 70$		
		24.4	K	100	5	
			N	$\pm 70$		
		22.3	K	100	6	
			N	$\pm 70$		
		20.7	K	100	7	
			N	$\pm 70$		
19.3	K	100	8			
	N	$\pm 70$				
18.2	K	100	9			
	N	$\pm 70$				
17.3	K	100	10			
	N	$\pm 70$				

Style	Isolation voltage (V)	Category temperature range ( $^{\circ}\text{C}$ )
MLP63C	100	-55~+170

### 3.2 Climatic category

55/170/56

Lower category temperature

-55  $^{\circ}\text{C}$

Upper category temperature

+170  $^{\circ}\text{C}$

Duration of the damp heat, steady state test

56days

### 3.3 Stability class

5%

Limits for change of resistance:

-for long-term tests  $\pm 5\%$

-for short-term tests  $\pm 1\%$

### 3.4 Derating

The derated values of dissipation at temperature in excess of 70 °C shall be as indicated by the following curve.

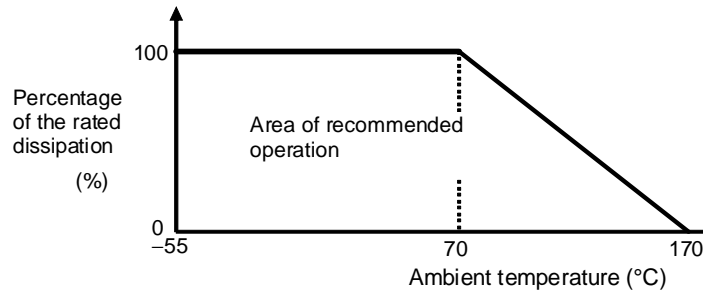

Figure-1 Derating curve

### 3.5 Rated voltage

d.c. or a.c. r.m.s. voltage calculated from the square root of the product of the rated resistance and the rated dissipation.

$$E = \sqrt{P \cdot R}$$

E: Rated voltage (V)

P: Rated dissipation (W)

R: Rated resistance ( $\Omega$ )

### 3.6 Rated current

The rated current calculated from the square root of the quotient of the rated resistance and the rated dissipation.

$$I = \sqrt{P / R}$$

I: Rated current (A)

P: Rated dissipation (W)

R: Rated resistance ( $\Omega$ )

The rated current shall be corresponding to rated voltage.

## 4. Packaging form

The standard packaging form shall be in accordance with Table-2.

Table-2

Symbol	Packaging form		Standard packaging quantity / units
TE	Embossed taping	12mm width, 4mm pitches	4,000 pcs.

## 5. Dimensions

5.1 The resistor shall be of the design and physical dimensions in accordance with Figure-2 and Table-3.

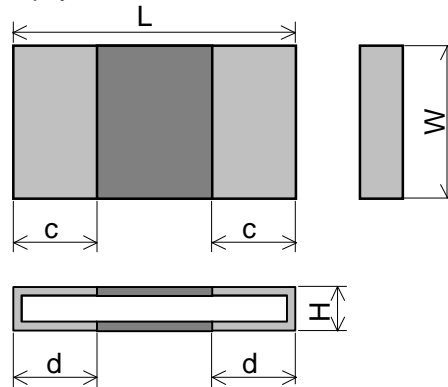

Figure-2  
Table-3

Unit: mm

Style	Rated resistance (mΩ)	L	W	H	c	d
MLP63C	0.5	6.3±0.25	3.1±0.25	0.58±0.15	2.2±0.25	2.2±0.25
	1			0.38±0.15	2.2±0.25	2.2±0.25
	1.5			0.38±0.15	1.5±0.25	1.5±0.25
	2			0.58±0.15	2.2±0.25	2.2±0.25
	2.5			0.45±0.15	2.4±0.25	2.4±0.25
	3			0.45±0.15	2.2±0.25	2.2±0.25
	4			0.34±0.15	2.2±0.25	2.2±0.25
	5			0.51±0.15	1.1±0.25	1.1±0.25
	6			0.5±0.15	1.1±0.25	1.1±0.25
	7			0.5±0.15	0.6±0.25	0.6±0.25
8	0.35±0.15	1.1±0.25	1.1±0.25			
9	0.35±0.15	0.8±0.25	0.8±0.25			
10	0.35±0.15	0.5±0.25	0.5±0.25			

## 5.2 Net weight (Reference)

Style	Rated resistance (mΩ)	Net weight (mg)
MLP63C	0.5	90
	1	50
	1.5	47
	2	77
	2.5	63
	3	63
	4	48
	5	64
	6	55
	7	55
8	43	
9	40	
10	41	

## 6. Marking

The rated resistance shall be marked in 4 characters consisting of 3 figures and a letter and marked on over coat side.

(Example) "R010" → 0.01 [Ω] → 10 [mΩ]

"1L50" → 0.0015 [Ω] → 1.5 [mΩ]

## 7. Performance

7.1 The standard condition for tests shall be in accordance with Sub-clause 4.2, JIS C 5201-1: 2011.

7.2 The performance shall be satisfied in Table-4.

Table-4(1)

No.	Test items	Condition of test (JIS C 5201-1)	Performance requirements													
1	Visual examination	Sub-clause 4.4.1 Checked by visual examination.	As in 4.4.1 The marking shall be legible, as checked by visual examination.													
2	Dimension Resistance	Sub-clause 4.4.2 Resistance value shall be measured by mounting the substrate of the following condition. <div style="text-align: center;"> <p style="text-align: center;">Unit:mm</p> <table border="1" style="margin-left: auto; margin-right: auto;"> <thead> <tr> <th>Style</th> <th>Resistance value(mΩ)</th> <th>a</th> <th>b</th> <th>c</th> </tr> </thead> <tbody> <tr> <td rowspan="2">MLP63C</td> <td>0.5, 1 to 4</td> <td>1.8</td> <td>2.9</td> <td rowspan="2">3.5</td> </tr> <tr> <td>1.5, 5 to 10</td> <td>4.0</td> <td>1.8</td> </tr> </tbody> </table> <p>Thickness of copper clad: 0.035mm 4-Terminal method Measurement current: 1(A) Note: The measuring apparatus corresponding to DC Low-ohm Meter (1A) of AX-1152D for ADEX CORPORATION.</p> </div>	Style	Resistance value(mΩ)	a	b	c	MLP63C	0.5, 1 to 4	1.8	2.9	3.5	1.5, 5 to 10	4.0	1.8	As specified in Table-3 of this specification. As in 4.5.2 The resistance value shall correspond with the rated resistance taking into account the specified tolerance.
Style	Resistance value(mΩ)	a	b	c												
MLP63C	0.5, 1 to 4	1.8	2.9	3.5												
	1.5, 5 to 10	4.0	1.8													
3	Voltage proof	Sub-clause 4.7 Method: 4.6.1.4(See Figure-5) Test voltage: Alternating voltage with a peak value of 1.42 times the insulation voltage. Duration: 60 s±5 s Insulation resistance Test voltage: Insulation voltage Duration: 1 min.	No breakdown or flash over  R ≥ 1 GΩ													

Table-4(2)

No	Test items	Condition of test (JIS C 5201-1)	Performance requirements
4	Solderability	Sub-clause 4.17 Without aging Flux: The resistors shall be immersed in a non-activated soldering flux for 2 s. Bath temperature: 235 °C±5 °C Immersion time: 2 s±0.5 s	As in 4.17.4.5 The terminations shall be covered with a smooth and bright solder coating.
5	Mounting  Overload (in the mounted state)  Solvent resistance of the marking	Sub-clause 4.31 Substrate material: Epoxide woven glass Test substrate: Figure-3-2 Sub-clause 4.13 The applied voltage shall be 2.5 times the rated voltage or the current corresponding to. Duration: 2 s Visual examination Resistance Sub-clause 4.30 Solvent: 2-propanol Solvent temperature: 23 °C±5 °C Method 1 Rubbing material: cotton wool Without recovery	No visible damage $\Delta R \leq \pm 1\%$ Legible marking
6	Mounting  Bound strength of the end face plating  Final measurements	Sub-clause 4.31 Substrate material: Epoxide woven glass Test substrate: Figure-4 Sub-clause 4.33 Bent value: 1 mm Resistance Sub-clause 4.33.6 Visual examination	$\Delta R \leq \pm 1\%$  No visible damage

Table-4(3)

No	Test items	Condition of test (JIS C 5201-1)	Performance requirements
7	Resistance to soldering heat          Component resistance solvent	Sub-clause 4.18 (JEITA RC-2144 2.3.2) Substrate material: Epoxide woven glass Test substrate: Figure-3-1 T <sub>1</sub> :Pre-heat minimum temp.:150±5 °C T <sub>2</sub> :Pre-heat maximum temp.:180±5 °C T <sub>3</sub> :Soldering temp.:220 °C T <sub>4</sub> :Peak temp.:250 °C t <sub>1</sub> :Pre-heat duration:120±5 s t <sub>2</sub> :Soldering duration:60 to 90 s t <sub>3</sub> :Peak duration(T <sub>4</sub> -5°C):20 to 40 s Pre-reflow soldering: 1 time (Initial measurements) Reflow soldering: 3 times  Visual examination Resistance Sub-clause 4.29 Solvent: 2-propanol Solvent temperature: 23 °C±5 °C Method 2 Recovery: 48 h Visual examination Resistance	No visible damage $\Delta R \leq \pm 1\%$          No visible damage $\Delta R \leq \pm 1\%$
8	Mounting  Adhesion   Rapid change temperature	Sub-clause 4.31 Substrate material: Epoxide woven glass Test substrate: Figure-3-1 Sub-clause 4.32 Force: 5 N Duration: 10 s±1 s Visual examination Sub-clause 4.19 Lower category temperature:-55 °C Upper category temperature:+155 °C Duration of exposure at each temperature: 30 min. Number of cycles: 5 cycles. Visual examination Resistance	No visible damage          No visible damage $\Delta R \leq \pm 1\%$



Table-4(4)

No	Test items	Condition of test (JIS C 5201-1)	Performance requirements
9	Climatic sequence -Dry heat  -Damp heat, cycle (12+12hour cycle) First cycle  -Cold  -Damp heat, cycle (12+12hour cycle) Remaining cycle  -D.C. load	Sub-clause 4.23 Sub-clause 4.23.2 Test temperature: +155 °C Duration: 16 h  Sub-clause 4.23.3 Test method: 2 Test temperature: 55 °C [Severity(2)]  Sub-clause 4.23.4 Test temperature -55 °C Duration: 2h  Sub-clause 4.23.6 Test method: 2 Test temperature: 55 °C [Severity (2)] Number of cycles: 5 cycles  Sub-clause 4.23.7 The applied current shall be the rated current. Duration: 1 min. Visual examination Resistance	No visible damage $\Delta R \leq \pm 5 \%$
10	Mounting  Endurance at 70 °C	Sub-clause 4.31 Substrate material: Epoxide woven glass Test substrate: Figure-3-2 Sub-clause 4.25.1 Ambient temperature: 70 °C±2 °C Duration: 1000 h The current shall be applied in cycles of 1.5 h on and 0.5 h. The applied current shall be the rated current Examination at 48 h, 500 h and 1000 h: Visual examination Resistance	No visible damage $\Delta R \leq \pm 5 \%$
11	Mounting  Variation of resistance with temperature	Sub-clause 4.31 Substrate material: Epoxide woven glass Test substrate: Figure-3-1 Sub-clause 4.8 +20 °C / +155 °C	As in Table-1

Table-4(5)

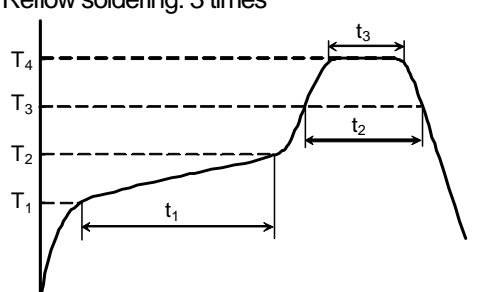
No	Test items	Condition of test (JIS C 5201-1)	Performance requirements
12	Mounting  Damp heat, steady state	Sub-clause 4.31 Substrate material: Epoxide woven glass Test substrate: Figure-3-1 Sub-clause 4.24 Ambient temperature: 40 °C±2 °C Relative humidity: 93 <sup>+2</sup> / <sub>-3</sub> % Without current applied. Visual examination  Resistance	No visible damage Legible marking $\Delta R \leq \pm 5\%$
13	Dimensions (detail)  Mounting  Endurance at upper category temperature	Sub-clause 4.4.3  Sub-clause 4.31 Substrate material: Epoxide woven glass Test substrate: Figure-3-1 Sub-clause 4.25.3 Ambient temperature: 170 °C±2 °C Duration: 1000 h Examination at 48 h, 500 h and 1000 h: Visual examination Resistance	As in Table-4      No visible damage $\Delta R \leq \pm 5\%$

## 8. Test substrate

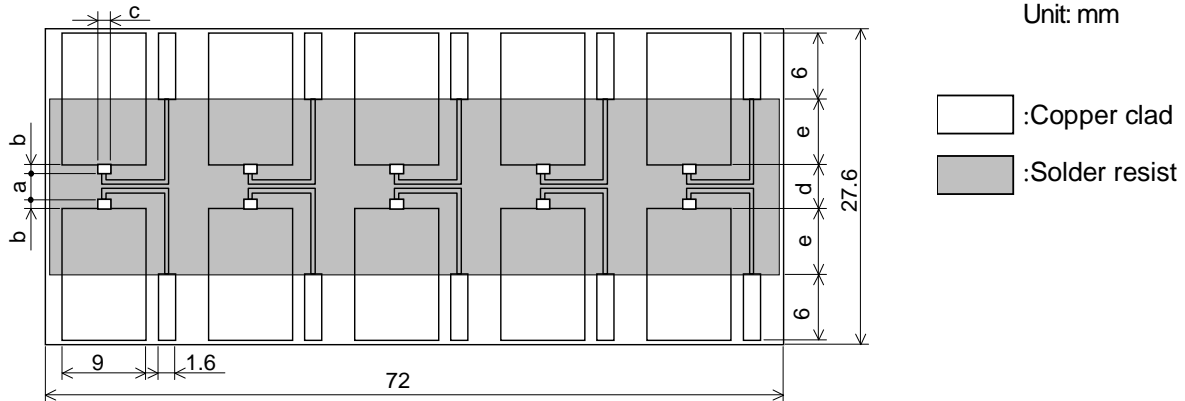

Style	Rated resistance (mΩ)	a	b	c	d	e
MLP63C	0.5, 1 to 4	1.8	2.9	3.5	7.6	3.5
	1.5, 5 to 10	4.0	1.8			

Figure-3-1 MLP63C TEST SUBSTRATE

Remark: Material: Epoxy resin based as glass fabric(Specified in JIS C 6484).

Thickness: 1.6mm      Thickness of copper clad: 0.035mm

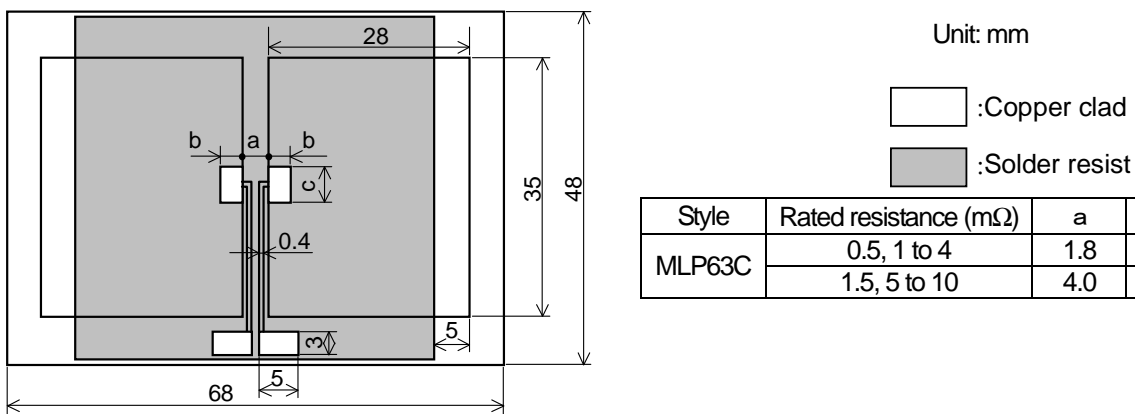

Style	Rated resistance (mΩ)	a	b	c
MLP63C	0.5, 1 to 4	1.8	2.9	3.5
	1.5, 5 to 10	4.0	1.8	

Figure-3-2 MLP63C TEST SUBSTRATE

Remark: Material: Epoxy resin based as glass fabric(Specified in JIS C 6484).

Thickness: 1.6mm      Thickness of copper clad: 0.07mm

Remark: In the case of connection by connector, the connecting terminals are gold plated.

However, the plating is not necessary when the connection is made by soldering.

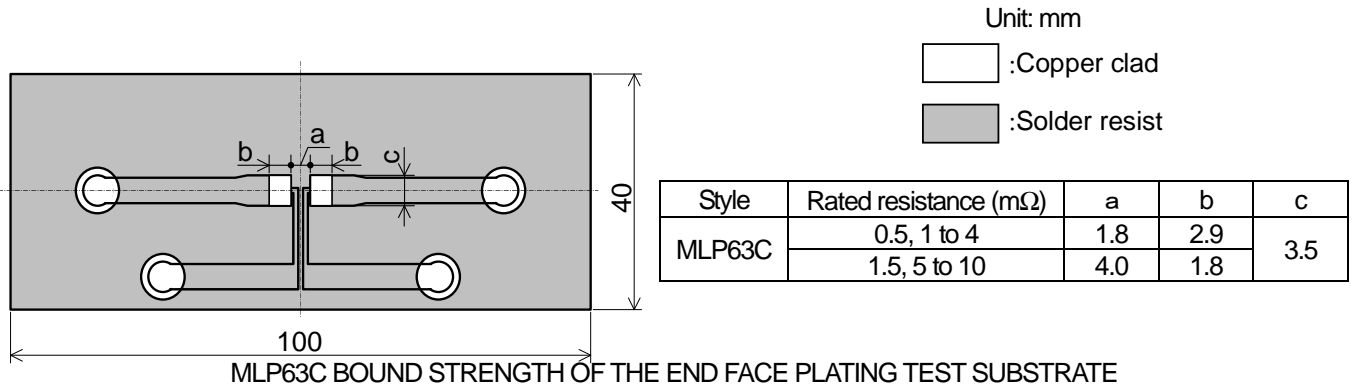

Figure-4

Remark. Material: Epoxy resin based as glass fabric(Specified in JIS C 6484).

Thickness: 1.6mm      Thickness of copper clad: 0.035mm

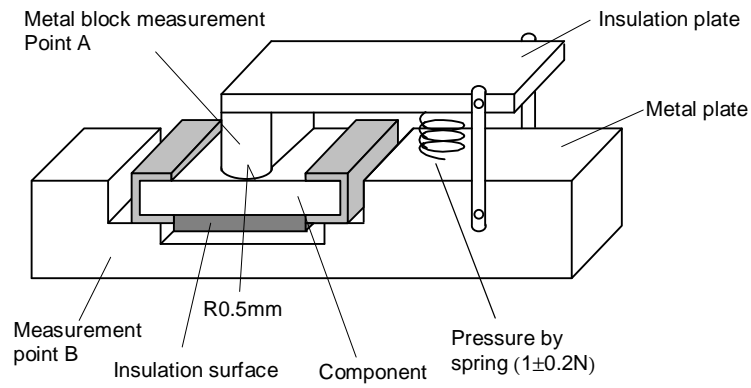

Figure-5

9. Taping

9.1 Applicable documents JIS C 0806-3: 2014, EIAJ ET-7200C: 2010

9.2 Taping dimensions

9.2.1 Embossed taping (12mm width, 4mm pitches)

Taping dimensions shall be in accordance with Figure-6 and Table-5.

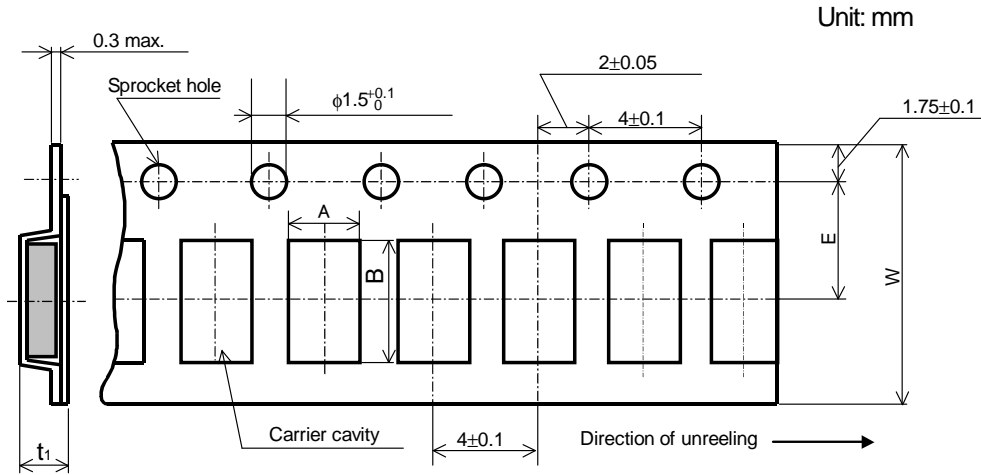

Figure-6

Table-5

Unit: mm

Style	A	B	W	E	$t_1$
MLP63C	$3.6 \pm 0.2$	$6.9 \pm 0.2$	$12.0 \pm 0.3$	$5.5 \pm 0.05$	$1.1 \pm 0.15$

- 1). The cover tapes shall not cover the sprocket holes.
- 2). Tapes in adjacent layers shall not stick together in the packing.
- 3). Components shall not stick to the carrier tape or to the cover tape.
- 4). Pitch tolerance over any 10 pitches  $\pm 0.2$ mm.
- 5). The peel strength of the top cover tape shall be within 0.1N to 0.5N on the test method as shown in the following Figure-7.
- 6). When the tape is bent with the minimum radius for 30mm, the tape shall not be damaged and the components shall maintain their position and orientation in the tape.
- 7). In no case shall there be two or more consecutive components missing.

The maximum number of missing components shall be one or 0.1%, whichever is greater.

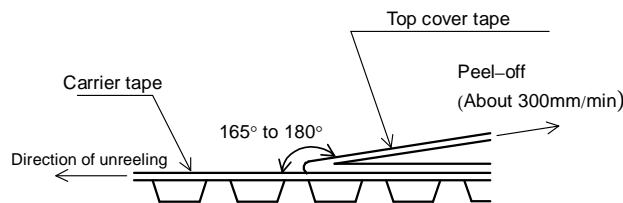

Figure-7

9.3 Reel dimension

Reel dimensions shall be in accordance with the following Figure-8 and Table-6.  
Plastic reel (Based on EIAJ ET-7200C)

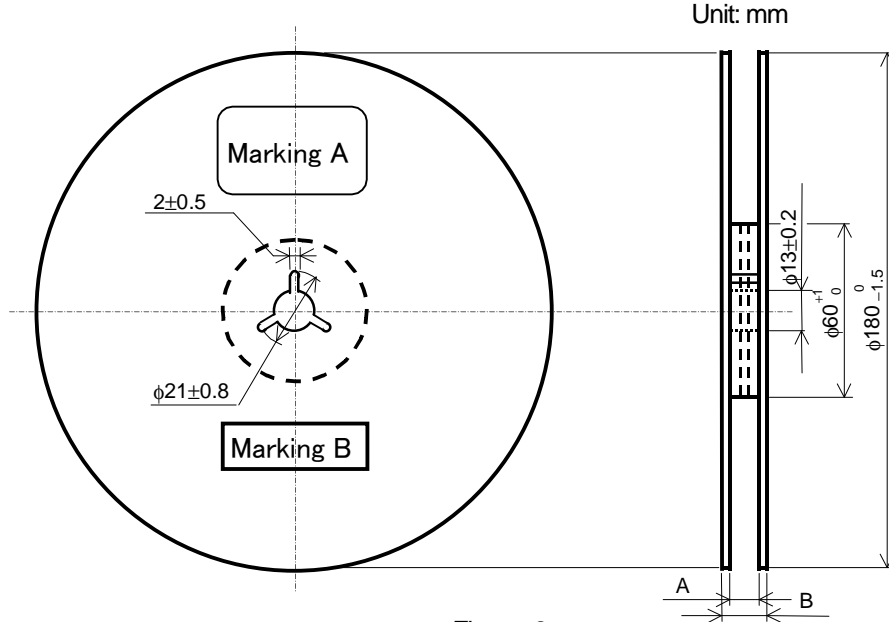

Figure-8

Table-6

Unit: mm

Style	A	B	Note
MLP63C	13 <sup>+1.0</sup> / <sub>0</sub>	17±1.0	Vacuum forming

Note : Marking label shall be marked on a place of Marking A or two place of Marking A and B.

9.4 Leader and trailer tape.

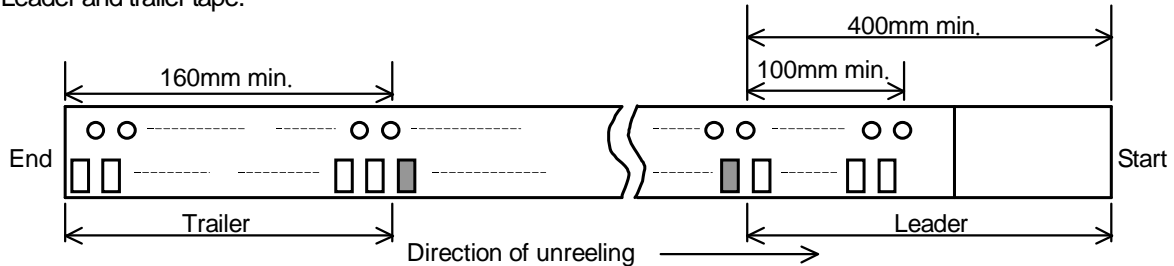

Figure-9

10. Marking on package

The label of a minimum package shall be legibly marked with follows.

10.1 Marking A

(1) Classification

(Style, Temperature coefficient of resistance, Rated resistance, Tolerance on rated resistance, Packaging form)

(2) Lot number (3) Quantity (4) Manufacturer's name or trade mark (5) Others

10.2 Marking B (KAMAYA Control label)