

Specification

Title: LINEAR POSITIVE T-C CHIP THERMISTORS;
RECTANGULAR TYPE

Style: LTC1/10,1/8

RoHS COMPLIANCE ITEM
Halogen and Antimony Free

Product specification contained in this specification
are subject to change at any time without notice
If you have any questions or a Purchasing Specification for any quality
Agreement is necessary, please contact our sales staff.



釜屋電機株式會社
KAMAYA ELECTRIC CO., LTD.

Hokkaido Research Center
Approval by: T. Sannomiya
Drawing by: M. Shibuya

Note: Stock conditions

Temperature: +5°C ~ +35°C

Relative humidity: 25% ~ 75%

The period of guarantee: Within 2 year from shipment by the company.

Solderability shall be satisfied.

1. Scope

1.1 This specification covers the detail requirements for linear positive T-C chip thermistors; rectangular type, style of LTC1/10,1/8.

1.2 Applicable documents

JIS C 5201-1: 2011, JIS C 5201-8: 2014, JIS C 5201-8-1: 2014
IEC60115-1: 2008, IEC60115-8: 2009, IEC60115-8-1: 2014
EIAJ RC-2134C-2010

2. Classification

Type designation shall be the following form.

(Example)

LTC	1/10	10	152	J	B
1	2	3	4	5	6

 Style

1 Linear positive T-C chip thermistors; rectangular type Style

2 Rated dissipation and/or dimension

3 Temperature coefficient of resistance

10	$\pm 1000 \times 10^{-6} / ^\circ\text{C}$
----	--

4 Rated resistance

152	E24 Series, 3 digit, Ex. 152--> 1.5k Ω
-----	---

5 Tolerance on rated resistance

J	$\pm 5\%$
---	-----------

6 Packaging form

B	Bulk (loose package)
TP	Paper taping

3. Rating

3.1 The ratings shall be in accordance with Table-1.

Table-1

Style	Rated dissipation (W)	Isolation voltage (V)	Category temperature range ($^\circ\text{C}$)
LTC1/10	0.1	100	-40~+125
LTC1/8	0.125		

3.2 Temperature coefficient of resistance and rated resistance .

3.2.1 The combination of temperature coefficient of resistance and rated resistance shall be in accordance with Table-2.

Table-2

Rated resistance		Tolerance	Temperature coefficient of resistance		
Resistance range			Symbol	Nominal value (10 ⁻⁶ °C)	Tolerance
LTC1/10	LTC1/8				
100Ω~5.1kΩ	100Ω~10kΩ	J(±5%)	05	500	±100×10 ⁻⁶ °C
100Ω~5.1kΩ	100Ω~10kΩ		08	800	±150×10 ⁻⁶ °C
100Ω~5.1kΩ	100Ω~10kΩ		10	1000	±15%
100Ω~3.3kΩ	100Ω~4.7kΩ		15	1500	
100Ω~3.3kΩ	100Ω~4.7kΩ		20	2000	±10%
100Ω~1.6kΩ	100Ω~2.2kΩ		24	2400	
100Ω~3.3kΩ	100Ω~3.6kΩ		28	2800	
100Ω~3.3kΩ	100Ω~3.6kΩ		30	3000	
100Ω~3.3kΩ	100Ω~3.6kΩ		33	3300	
51Ω~910Ω	51Ω~1.2kΩ		36	3600	
51Ω~560Ω	51Ω~910Ω		39	3900	
33Ω~360Ω	33Ω~470Ω		42	4200	
33Ω~200Ω	33Ω~180Ω		45	4500	

3.2.2 The symbol of the temperature coefficient of resistance

The symbol of the temperature coefficient of resistance shall be in accordance with Table-2.

Example) 05.....500×10⁻⁶°C
 10.....1,000×10⁻⁶°C

3.2.3 Symbols for rated resistance

The symbol of the rated resistance shall be combined one English capital letter and one digit in accordance with Table-3 and Table-4.

Table-3

Code	A	B	C	D	E	F	G	H	J	K	L	M
Value	1.0	1.1	1.2	1.3	1.5	1.6	1.8	2.0	2.2	2.4	2.7	3.0

Code	N	P	Q	R	S	T	U	V	W	X	Y	Z
Value	3.3	3.6	3.9	4.3	4.7	5.1	5.6	6.2	6.8	7.5	8.2	9.1

Table-4

Code	0	1	2	3	4
Multiplier	10 ⁰	10 ¹	10 ²	10 ³	10 ⁴

Example) A1.....1.0×10¹=10Ω
 E3.....1.5×10³=1.5kΩ

3.3 Climatic category

40/125/56

Lower category temperature -40 °C
 Upper category temperature +125 °C
 Duration of the damp heat, steady state test 56days

3.4 Stability class

5%

Limits for change of resistance:

-for long - term tests ±(5%+0.1Ω)
 -for short - term tests ±(1%+0.05Ω)

3.5 Derating

The derated values of dissipation at temperature in excess of 70 °C shall be as indicated by the following curve.

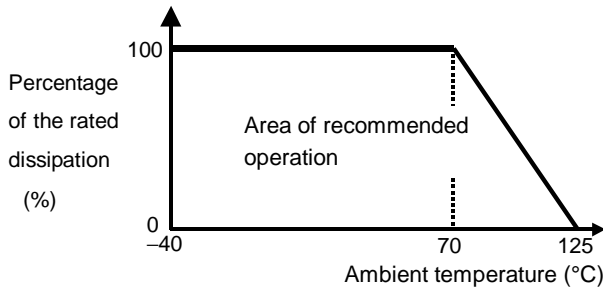

Figure-1 Derating curve

3.6 Rated voltage

d. c. or a. c. r. m. s. voltage calculated from the square root of the product of the rated resistance and the rated dissipation.

$$E = \sqrt{P \cdot R}$$

E : Rated voltage (V)
P : Rated dissipation (W)
R : Rated resistance (Ω)

4. Packaging form

The standard packaging form shall be in accordance with Table-5.

Table-5

Symbol	Packaging form		Standard packaging quantity / units
B	Bulk (loose package)		1,000 pcs.
TP	Paper taping	8mm width, 4mm pitches	5,000 pcs.

5. Dimensions

5.1 The resistor shall be of the design and physical dimensions in accordance with Figure-2 and Table-6.

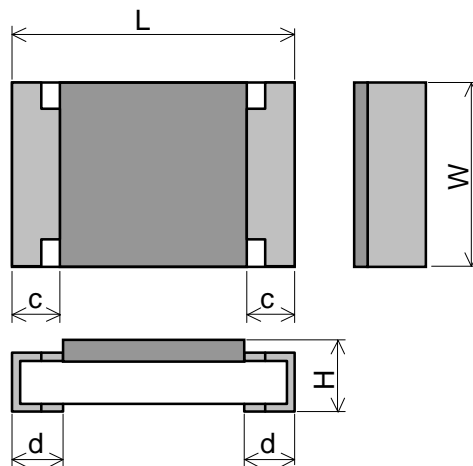

Figure-2

Table-6

Unit : mm

Style	L	W	H	c	d
LTC1/10	2.0 ± 0.15	1.25 ^{+0.10} / _{-0.05}	0.6 ± 0.1	0.4 ± 0.2	0.3 ^{+0.2} / _{-0.1}
LTC1/8	3.1 ± 0.1	1.55 ± 0.10	0.6 ± 0.1	0.45 ± 0.20	0.3 ^{+0.2} / _{-0.1}

5.2 Net weight (Reference)

Style	Net weight(mg)
LTC1/10	5
LTC1/8	9

6. Marking

The combination symbol of nominal resistance value and temperature coefficient of resistance shall be marked on over coat side as shown in following examples.

(Example) 10E3.....1,000×10⁻⁶/°C,1.5kΩ
10K2.....3,900×10⁻⁶/°C,240Ω

7. Performance

7.1 The standard condition for tests shall be in accordance with Sub-clause 4. 2, JIS C 5201-1: 2011.

7.2 The performance shall be satisfied in Table-7.

Table-7(1)

No.	Test items	Condition of test (JIS C 5201 - 1)	Performance requirements
1	Visual examination	Sub-clause 4. 4. 1 Checked by visual examination.	As in 4. 4. 1 The marking shall be legible, as checked by visual examination.
2	Dimension Resistance	Sub-clause 4. 4. 2 Sub-clause 4. 5	As specified in Table-6 of this specification. As in 4. 5. 2 The resistance value shall correspond with the rated resistance taking into account the specified tolerance.
3	Voltage proof	Sub-clause 4. 7 Method: 4. 6. 1. 4(See Figure-5) Test voltage: Alternating voltage with a peak value of 1.42 times the insulation voltage. Duration: 60 s ± 5 s Insulation resistance Test voltage : Insulation voltage Duration: 1 min.	No breakdown or flash over R ≥ 1 G Ω
4	Solderability	Sub-clause 4. 17 Without ageing Flux: The thermistors shall be immersed in a non - activated soldering flux for 2s. Bath temperature: 235 °C ± 5 °C Immersion time: 2 s ± 0.5 s	As in 4. 17. 4. 5 The terminations shall be covered with a smooth and bright solder coating.

Table-7(2)

No	Test items	Condition of test (JIS C 5201 - 1)	Performance requirements
5	Mounting Overload (in the mounted state) Solvent resistance of the marking	Sub-clause 4. 31 Substrate material: Epoxide woven glass Test substrate: Figure-3 Sub-clause 4. 13 The applied voltage shall be 2.5 times the rated voltage. Duration: 2 s Visual examination Resistance Sub-clause 4. 30 Solvent : 2 - propanol Solvent temperature: 23 °C ± 5 °C Method 1 Rubbing material: cotton wool Without recovery	No visible damage $\Delta R \leq \pm (1\%+0.05\Omega)$ Legible marking
6	Mounting Bound strength of the end face plating Final measurements	Sub-clause 4. 31 Substrate material: Epoxide woven glass Test substrate: Figure-4 Sub-clause 4. 33 Bent value: 3 mm Resistance Sub-clause 4. 33. 6 Visual examination	$\Delta R \leq \pm (1\%+0.05\Omega)$ No visible damage
7	Resistance to soldering heat Component solvent resistance	Sub-clause 4. 18 Solder temperature: 260 °C ± 5 °C Immersion time: 10 s ± 0. 5 s Visual examination Resistance Sub-clause 4.29 Solvent: 2-propanol Solvent temperature: 23 °C ± 5 °C Method 2 Recovery: 48 h Visual examination Resistance	As in 4. 18. 3. 4 No sign of damage such as cracks. $\Delta R \leq \pm (1\%+0.05\Omega)$ No visible damage $\Delta R \leq \pm (1\%+0.05\Omega)$

Table-7(3)

No	Test items	Condition of test (JIS C 5201 - 1)	Performance requirements
8	Mounting Adhesion Rapid change temperature	Sub-clause 4. 31 Substrate material: Epoxide woven glass Test substrate: Figure-3 Sub-clause 4. 32 Force: 5 N Duration: 10 s ± 1 s Visual examination Sub-clause 4.19 Lower category temperature: -40 °C Upper category temperature: +85 °C Duration of exposure at each temperature: 30 min. Number of cycles: 5 cycles. Visual examination Resistance	No visible damage No visible damage $\Delta R \leq \pm(1\%+0.05\Omega)$
9	Climatic sequence -Dry heat -Damp heat, cycle (12+12hour cycle) First cycle -Cold -Damp heat, cycle (12+12hour cycle) Remaining cycle -D.C. load	Sub-clause 4. 23 Sub-clause 4. 23. 2 Test temperature: +125 °C Duration: 16 h Sub-clause 4. 23. 3 Test method: 2 Test temperature: 55 °C [Severity(2)] Sub-clause 4. 23. 4 Test temperature -40 °C Duration: 2h Sub-clause 4. 23. 6 Test method: 2 Test temperature: 55 °C [Severity (2)] Number of cycles: 5 cycles Sub-clause 4. 23. 7 The applied voltage shall be the rated voltage Duration: 1 min. Visual examination Resistance	No visible damage $\Delta R \leq \pm (5\%+0.1\Omega)$
10	Mounting Endurance at 70 °C	Sub-clause 4. 31 Substrate material: Epoxide woven glass Test substrate: Figure - 3 Sub-clause 4. 25. 1 Ambient temperature: 70 °C ± 2 °C Duration: 1000 h The voltage shall be applied in cycles of 1.5 h on and 0.5 h. The applied voltage shall be the rated voltage Examination at 48 h , 500 h and 1000 h: Visual examination Resistance	No visible damage $\Delta R \leq \pm (5\%+0.1\Omega)$

Table-7(4)

No	Test items	Condition of test (JIS C 5201-1)	Performance requirements
11	Mounting Variation of resistance with temperature	Sub - clause 4. 31 Substrate material: Epoxide woven glass Test substrate: Figure-3 Sub-clause 4. 8 +20 °C / + 75°C	As in Table-2
12	Mounting Damp heat, steady state	Sub-clause 4. 31 Substrate material: Epoxide woven glass Test substrate: Figure-3 Sub-clause 4. 24 Ambient temperature: 40 °C ± 2 °C Relative humidity : 93 \pm ₃ % Without voltage applied. Without polarizing voltage [4. 24. 2. 1, c)] Visual examination Resistance	No visible damage Legible marking $\Delta R \leq \pm (5\%+0.1\Omega)$
13	Dimensions (detail) Mounting Endurance at upper category temperature	Sub-clause 4. 4. 3 Sub-clause 4. 31 Substrate material: Epoxide woven glass Test substrate: Figure-3 Sub-clause 4. 25. 3 Ambient temperature:125 °C ± 2 °C Duration: 1000 h Examination at 48 h, 500 h and 1000 h: Visual examination Resistance	As in Table-6 No visible damage $\Delta R \leq \pm (5\%+0.1\Omega)$

8. Test substrate

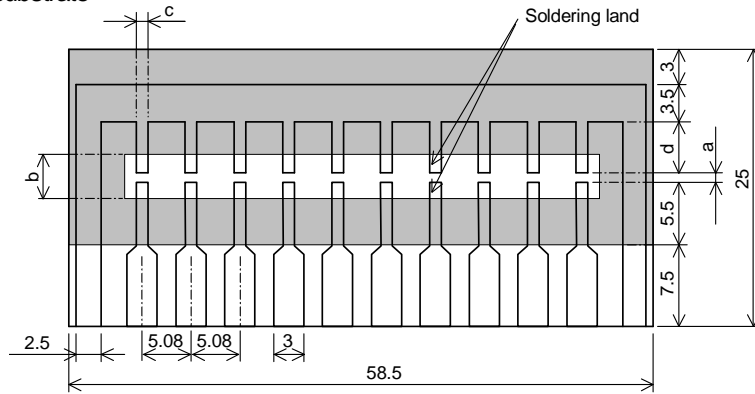

Unit: mm

□ :Copper clad
■ :Solder resist

Style	a	b	c	d
LTC1/10	1.2	4.0	1.5	4.3

LTC1/10 TEST SUBSTRATE

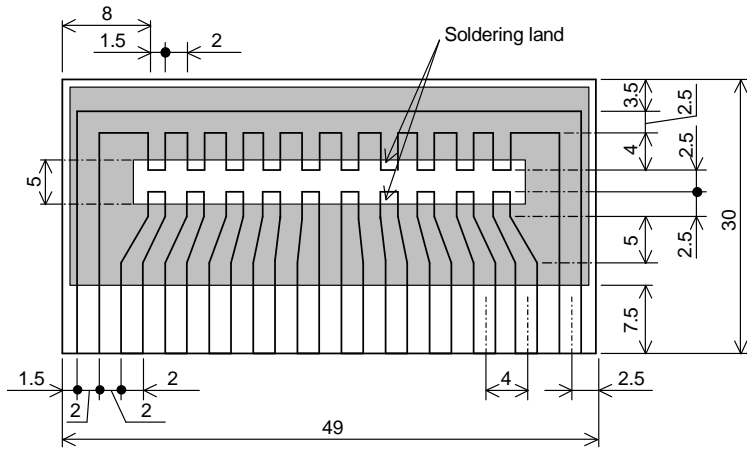

□ :Copper clad
■ :Solder resist

LTC1/8 TEST SUBSTRATE

Figure-3

- Remark 1). Material: Epoxide woven glass
Thickness: 1.6mm Thickness of copper clad: 0.035mm
- 2). In the case of connection by connector, the connecting terminals are gold plated.
However, the plating is not necessary when the connection is made by soldering.

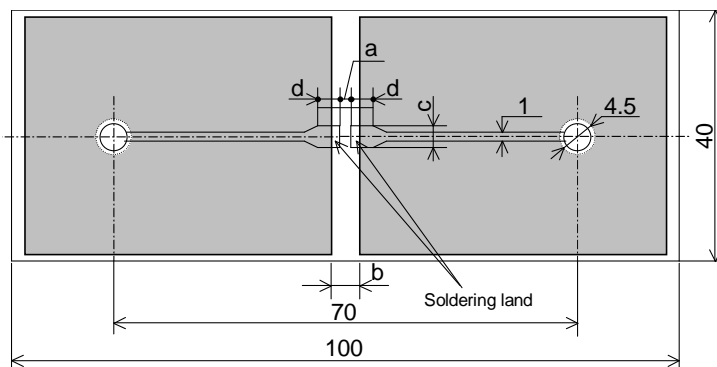

Unit: mm

□ :Copper clad
■ :Solder resist

Style	a	b	c	d
LTC1/10	1.2	4.0	1.65	3.0
LTC1/8	2.5	5.0	2.0	2.5

- Remark 1). Material: Epoxide woven glass
Thickness: 1.6mm Thickness of copper clad: 0.035mm

Figure-4 LTC BOUND STRENGTH OF THE END FACE PLATING TEST SUBSTRATE

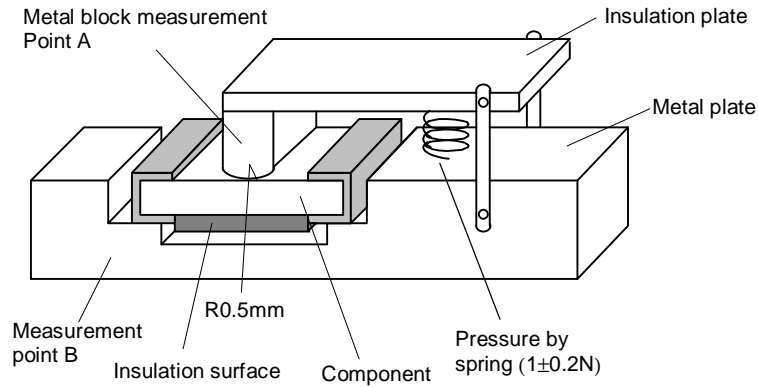

Figure-5

9. Taping

9.1 Applicable documents JIS C 0806-3: 2014, EIAJ ET-7200C: 2010

9.2 Taping dimensions

Taping dimensions shall be in accordance with Figure-6 and Table-8.

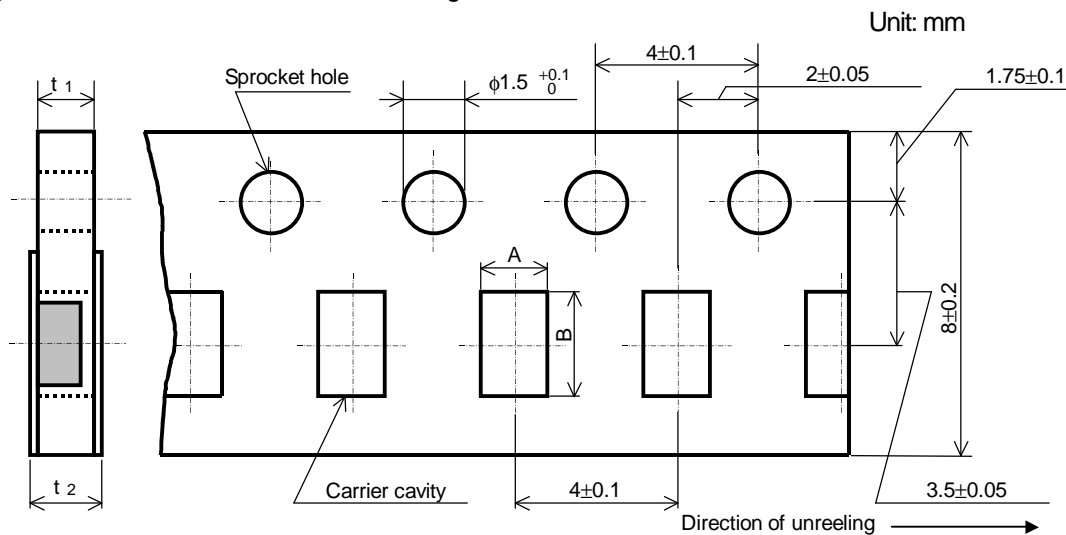

Figure-6

Table-8

Unit: mm

Style	A	B	t ₁	t ₂
LTC1/10	1.65 ± 0.15	2.5 ± 0.2	0.8 ± 0.1	1.0max.
LTC1/8	2.0 ± 0.15	3.6 ± 0.2		

- 1). The cover tapes shall not cover the sprocket holes.
- 2). Tapes in adjacent layers shall not stick together in the packing.
- 3). Components shall not stick to the carrier tape or to the cover tape.
- 4). Pitch tolerance over any 10 pitches $\pm 0.2\text{mm}$.
- 5). The peel strength of the top cover tape shall be with in 0.1N to 0.5N on the test method as shown in the following Figure-7.
- 6). When the tape is bent with the minimum radius for 25 mm, the tape shall not be damaged and the components shall maintain their position and orientation in the tape.
- 7). In no case shall there be two or more consecutive components missing.
The maximum number of missing components shall be one or 0. 1%, whichever is greater..
- 8). The thermistors shall be faced to upward at the over coating side in the carrier cavity.

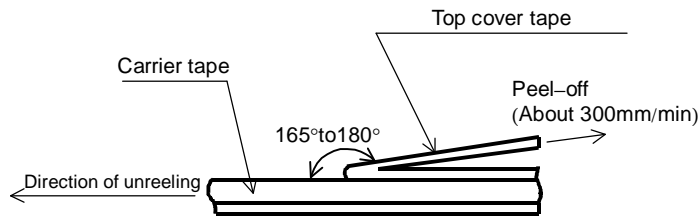

Figure-7

9.3 Reel dimension

Reel dimensions shall be in accordance with the following Figure-8 and Table-9.

Plastic reel (Based on EIAJ ET-7200C)

Unit: mm

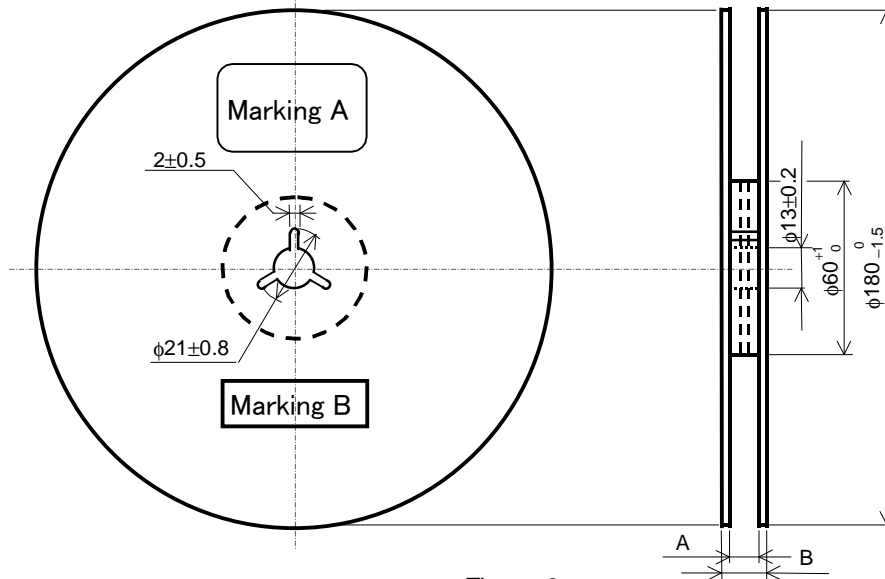

Figure-8

Table-9

Unit: mm

Style	A	B	Note
LTC1/10,1/8	9 ^{+1.0} / ₀	11.4±1.0	Injection molding
		13±1.0	Vacuum forming

Note: Marking label shall be marked on a place of Marking A or two place of marking A and B.

9.4 Leader and trailer tape.

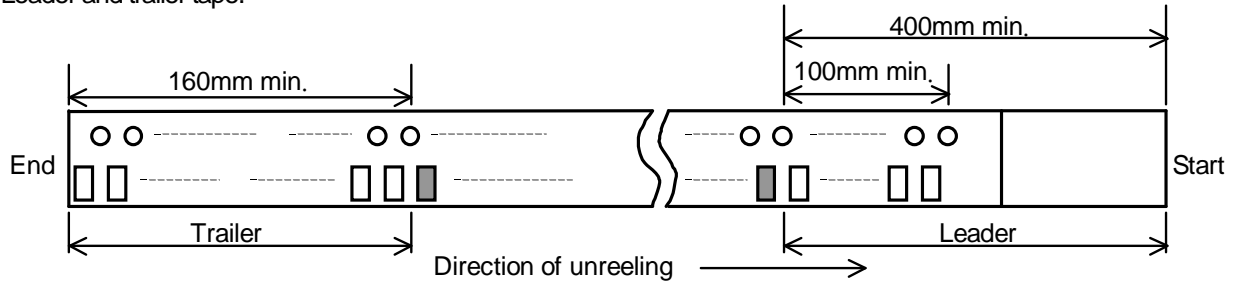

Figure-9

10. Marking on package

The label of a minimum package shall be legibly marked with follows.

10.1 Marking A

(1) Classification

(Style, Temperature coefficient of resistance, Rated resistance, Tolerance on rated resistance, Packaging form)

(2) Quantity (3) Lot number (4) Manufacturer's name or trade mark (5) Others

10.2 Marking B(KAMAYA Control label)